



CREATIVE
COMPOSITES
GROUP

Development of Design Properties for the Series 1580 Seawall Profile



Comparison and Validation of Load & Resistance Factor Design (LRFD) and Finite Element Analysis (FEA) of Non-Conforming Profiles





Contents



Introduction	1
Panel Description	1
Analysis	2
Pre-Standard Calculation	2
FEA Calculation	3
Experimental Testing	4
Summary	5
Conclusions	5

Abstract

This paper demonstrates three methods to determine the moment capacity of Fiber Reinforced Polymer (FRP) sheet piling. Composite sheet piling is susceptible to local compression failure prior to reaching the material strength capacity. The low modulus of elasticity in conjunction with the unsupported flange width and thickness greatly affects the true moment capacity of non-metallic sheet piling. This paper describes two modeling methods and the degree of error as compared to a full section cantilever test of the sheet pile wall modeled.

Prepared by:

Jeremy Mostoller

Product Design Engineer

Dustin Troutman

Vice President of Sales and Marketing

Introduction

The American Composites Manufacturing Association (ACMA) has developed the Pre-Standard for Load & Resistance Factor Design (LRFD) of Pultruded Fiber Reinforced Polymer (FRP) Structures in conjunction with the American Society of Civil Engineers (ASCE). The design equations included in the Pre-Standard were derived based on standard cross-section profiles common throughout the pultrusion manufacturing community. Many of the equations were developed assuming the profiles consist of flat plates arranged at 90-degree angles, and typically are singly or doubly symmetric. Most pultrusion companies have developed custom profiles that do not conform to these conditions.

This report details an investigation of the Creative Pultrusions, Inc. (CPI) Series 1580 seawall profile. Comparisons were made between the Pre-Standard rectangular tube model, Finite Element Analysis (FEA) results, and full section testing to determine the effectiveness for non-conforming profiles.

Pre-Standard for
Load & Resistance Factor
Design (LRFD) of Pultruded
Fiber Reinforced Polymer (FRP)
Structures
(Final)

Submitted to:
American Composites Manufacturers
Association (ACMA)

November 9, 2010



Panel Description

Moment of inertia: $54.01 \text{ in}^4/\text{ft}$

Section Modulus: $13.08 \text{ in}^3/\text{ft}$

Width of Sheet: 18 in

Weight (Single Sheet): $4.05 \text{ lb}/\text{ft}^2$

Cross Sectional Area: 7.43 in^2

The Series 1580 seawall profile is a Z-section with a web angle of 120° (Figure 1). Interlocking features are integral along each edge of the part so the panels can be joined together to form a single structure. The interlocking connector causes analysis difficulty because it creates a boundary condition at the center of the tension/compression face with a rotational degree of freedom.

The panels are installed in a vertical position, often in a cantilever load condition. The thin wall section is subject to buckling due to the relatively low modulus of the section and the long flat sections of the part. Section properties of the wall are listed on the left.

Figure 1: Schematic of Series 1580 seawall profile

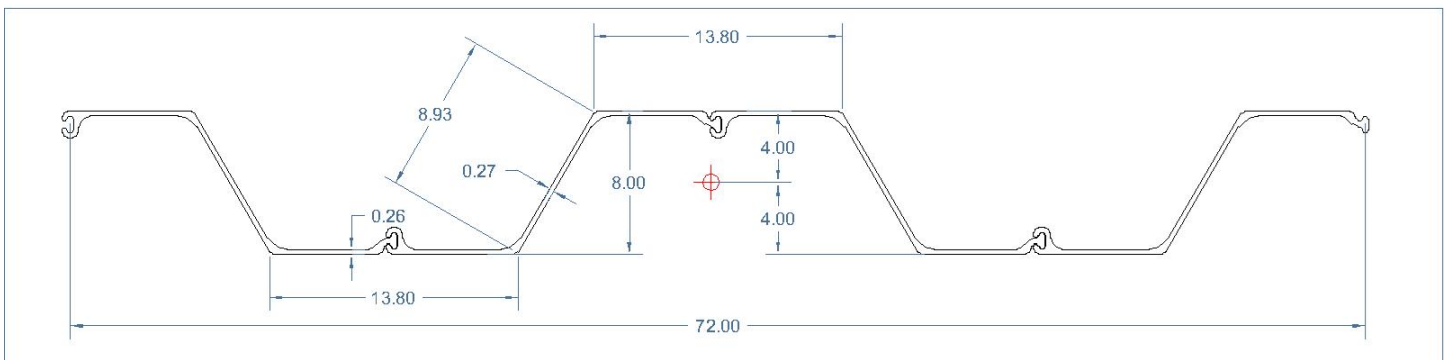

Analysis

$E_{L,f} = E_{L,w} = 4250 \text{ ksi}$
Longitudinal modulus

$E_{T,f} = E_{T,w} = 1300 \text{ ksi}$
Transverse modulus

$G_{LT} = 500 \text{ ksi}$
In-plane shear modulus

$\nu_{LT} = 0.3$
Longitudinal Poisson's ratio

$b_f = 13.8 \text{ in}$
Full width of flange

$t_f = t_w = 0.265 \text{ in}$
Thickness of flange

$h = 8 \text{ in}$
Full height of member

$I = 54.1 \text{ in}^4$
Moment of inertia of the profile about the axis of bending

An analysis was conducted using the Pre-Standard rectangular tube design equations and FEA. Coupon level testing had been conducted to determine the nominal and characteristic material properties and strengths as specified within the Pre-Standard. Nominal material properties were used for the analysis to compare to the full section physical testing. In an effort of conservativeness in the calculation, the minimum value of each property was chosen from the available test results (tension/compression, flange/web).

Pre-Standard Calculation

The capacity of the panel was calculated using the flexural loading of a rectangular tube section of the Pre-Standard. The rectangular tube model was chosen because this most closely represents the interaction of the web-flange interface.

Section 5.2.3.4 of the Pre-Standard provides the equations used for the analysis of the panel. The calculation resulted in a critical compression flange local buckling value of 12,843 psi. This value correlates to a predicted failure moment of 13,998 ft-lb/ft of wall. Standard cantilever beam calculations predict the failure load of the full section test to be 8,764 lb at a deflection of 3.221".

The coupon level compression strength for the part was measured to have an average value of 70,160 psi. Therefore, the panel is predicted to buckle well below the material rupture strength.

Equation 1: Pre-Standard Buckling Equations for Square and Rectangular Box Members

(a) *Compression flange local buckling*

$$f_{cr} = \frac{4\pi^2 t_f^2}{b_f^2} \left(\frac{\sqrt{(E_{L,f} E_{T,f})(1 + 4.1\xi)}}{6} + \left(2 + 0.62\xi^2 \right) \left(\frac{E_{T,f} \nu_{LT}}{12} + \frac{G_{LT}}{6} \right) \right) \quad (5.2.3.4-1)$$

with

$$\xi = \frac{1}{1 + \frac{4E_{T,f} t_f^3}{5k_r b_f}} \quad (5.2.3.4-2)$$

$$k_r = \frac{E_{T,w} t_w^3}{3h} \left(1 - \left[\frac{2t_f^2 h^2 E_{L,f}}{11.1 b_f^2 t_w^2 E_{L,f}} \left(\frac{\sqrt{E_{L,f} E_{T,f}} + E_{T,f} \nu_{LT} + 2G_{LT}}{1.25 \sqrt{E_{L,w} E_{T,w}} + E_{T,w} \nu_{LT} + 2G_{LT}} \right) \right] \right) \quad (5.2.3.4-3)$$

(b) *Web local buckling*

$$f_{cr} = \frac{11.1\pi^2 t_w^2}{6h^2} \left(1.25 \sqrt{E_{L,w} E_{T,w}} + E_{T,w} \nu_{LT} + 2G_{LT} \right) \quad (5.2.3.4-4)$$

FEA Calculation

Figure 2: FEA Model Showing the First Buckling Modes

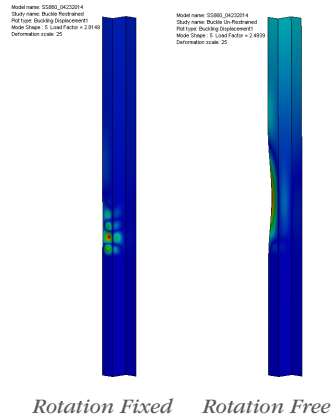

An FEA model was created using SolidWorks Simulation that mimics the full section test. The model uses shell elements at the neutral axis of the laminate with beam elements to represent the heavy interlock feature. A single panel was modeled with boundary conditions applied to represent a continuous wall. Linear static stress and Eigen value buckling analyses were performed using the model. A load of 1000 lb was applied to the model at the wale location, and linear scaling was performed for comparison to the Pre-Standard analysis and test results.

Difficulty occurs in the modeling process in representing the panel interlock feature. The interlock feature has a measurable amount of clearance in the interface, which allows for some rotation at the interface.

The Eigen value analysis was solved using two different sets of boundary conditions. One analysis was performed with the longitudinal rotation fixed at the interlock location. A second run was performed with the longitudinal rotation free. Both predict local buckling in the compression flange, but with slightly different modal shapes. The Eigen values predicted by the model are 2.8149 and 2.4939 for the rotation-fixed and rotation-free runs, respectively. These values correlate to applied loads of 11,260 lb and 9,976 lb for the full section test.

Figure 3: FEA Model Showing the Displacement and LW Stress Contour Plots

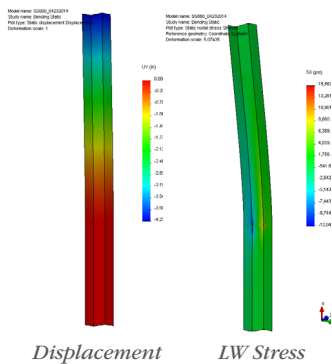

The linear static analysis predicted a displacement at the bottom edge of the waler of 3.107" for the 1000 lb load. This correlates to a displacement at the predicted failure loads of 8.75" and 7.75" for the rotation-fixed and rotation-free models, respectively. The peak compression stress predicted by the model is 12,044 psi. This correlates to a factor of safety of 5.35, which suggests the part will buckle prior to material rupture.

Experimental Testing

Figure 4: Full Section Test Setup



Full scale testing was conducted to determine the accuracy of the analysis. The test was performed using four pieces of the profile interlocked to make a structure 72" wide. The panels were 18 ft long and embedded in compacted gravel at a depth of approximately 6 ft. Wale sections were mounted to the panel at 9ft, 7in above the groundline to create a rigid location to apply load and prevent distortion of the wall section. Load was applied by running cables from the wale section to a backhoe bucket. West Virginia University Constructed Facilities Center was on hand during the test to perform the instrumentation and data recording, and to oversee the testing.

Figure 5: Full Section Test Failure



A buckling failure of the panel occurred at a load of 10,374 lb. This value correlates to a groundline moment of 16,569 ft-lb/ft of wall and a flange compression stress of 15,201 psi. The deflection at the wale location was 18.7 inches at failure. It was observed the compacted gravel gave way on the front side of the panels resulting in a 1- to 2-inch gap on the back of the panels. This soil displacement may have contributed to additional measured deflection of 8.5 inches resulting from rigid body motion. Strain gages mounted on the panels indicate the section performed as a well-behaved cantilever beam with uniform load distribution across the width of the structure.



Summary

The Pre-Standard analysis results in a conservative prediction of failure for the Series 1580 sheet pile. The value predicted is 15.5% less than the full section test result. This error is easily explainable with the conservative assumptions made for the Pre-Standard calculations. In particular, the material property values were assumed to be the minimum value from the coupon level testing. If these values are changed to median values of the test results, the Pre-Standard is only 4% conservative.

The FEA showed good correlation with the full section test results. The two boundary conditions bounded the test results, with the rotation-fixed analysis overpredicting the test result by 8.5% and the rotation-free analysis underpredicting the test result by 3.8%.

The deflection prediction did not correlate with the full section testing as well as the failure prediction. The boundary condition of the soil is the most likely cause of the poor prediction. The soil provides an elastic foundation that allowed the panels to move. The Pre-Standard calculation was performed as a cantilever beam, which assumes no displacement at or below the groundline. The FEA was performed with the normal vector of displacement fixed for each face. This allowed for some shear deflection below groundline but no bending displacement.

Conclusions

Material strength comparisons are not sufficient to determine the capacity of the FRP sheet pile. Buckling calculations must be performed to properly predict the failure of these thin wall, low modulus structural profiles. This paper shows the Pre-Standard buckling calculations or FEA are both options for determining conservative strength capacities of the assembled structure

ABOUT THE COMPANY

Creative Composites Group is a custom design, engineering and Fiber Reinforced Polymer (FRP) fabrication provider. We offer comprehensive engineering, design and consultation for unique fabrication projects. Our manufacturing capabilities include the broadest range of engineered FRP solutions to build your ideal projects. That's possible only with our proven engineering processes, end-to-end collaboration, service and support resources. Since FRP composites last longer than conventional materials they often have a lower lifetime cost when you consider longer service life and low to no maintenance costs.



Creative Composites Group

214 Industrial Lane
Alum Bank, PA 15521

CreativeCompositesGroup.com

CCGWP11012021R1
© 2022 Creative Composites Group
All Rights Reserved Worldwide